

# *Grizzly* *Industrial, Inc.*®

## MODEL T10687

## TRACK SAW

## OWNER'S MANUAL

*(For models manufactured since 10/12)*



COPYRIGHT © OCTOBER, 2012 BY GRIZZLY INDUSTRIAL, INC. REVISED JANUARY, 2013 (TR)

**WARNING: NO PORTION OF THIS MANUAL MAY BE REPRODUCED IN ANY SHAPE  
OR FORM WITHOUT THE WRITTEN APPROVAL OF GRIZZLY INDUSTRIAL, INC.**

#JM15261 PRINTED IN CHINA



## **WARNING!**

**This manual provides critical safety instructions on the proper setup, operation, maintenance, and service of this machine/tool. Save this document, refer to it often, and use it to instruct other operators.**

**Failure to read, understand and follow the instructions in this manual may result in fire or serious personal injury—including amputation, electrocution, or death.**

**The owner of this machine/tool is solely responsible for its safe use. This responsibility includes but is not limited to proper installation in a safe environment, personnel training and usage authorization, proper inspection and maintenance, manual availability and comprehension, application of safety devices, cutting/sanding/grinding tool integrity, and the usage of personal protective equipment.**

**The manufacturer will not be held liable for injury or property damage from negligence, improper training, machine modifications or misuse.**



## **WARNING!**

**Some dust created by power sanding, sawing, grinding, drilling, and other construction activities contains chemicals known to the State of California to cause cancer, birth defects or other reproductive harm. Some examples of these chemicals are:**

- **Lead from lead-based paints.**
- **Crystalline silica from bricks, cement and other masonry products.**
- **Arsenic and chromium from chemically-treated lumber.**

**Your risk from these exposures varies, depending on how often you do this type of work. To reduce your exposure to these chemicals: Work in a well ventilated area, and work with approved safety equipment, such as those dust masks that are specially designed to filter out microscopic particles.**

# Table of Contents

<b>INTRODUCTION.....</b>	<b>2</b>
Manual Accuracy.....	2
Contact Info.....	2
Glossary Of Terms.....	3
Features and Controls.....	4
<b>SECTION 1: SAFETY.....</b>	<b>8</b>
Safety Instructions for Power Tools.....	8
Additional Safety for Circular Saws.....	10
Understanding Kickback.....	11
Preventing.....	11
Kickback.....	11
<b>SECTION 2: POWER SUPPLY.....</b>	<b>12</b>
<b>SECTION 3: SETUP.....</b>	<b>14</b>
Unpacking.....	14
Included Inventory.....	14
Optional Accessories.....	14
Dust Collection.....	15
<b>SECTION 4: OPERATIONS.....</b>	<b>16</b>
Using the Saw.....	16
Blade Selection.....	16
Changing Blades.....	16
Riving Knife Adjustment.....	18
Setting Cutting Depth.....	19
Setting Cutting Angle.....	20
Making Straight Cuts.....	20
Making Plunge Cuts.....	21
Using Rail Track.....	23
Adding Rail Tracks.....	23
Using Adjustable Stop.....	24
Using the Stabilizer.....	24
<b>SECTION 5: MAINTENANCE.....</b>	<b>25</b>
Electrical.....	25
Cleaning.....	25
Lubrication.....	25
Blade.....	25
<b>SECTION 6: SERVICE.....</b>	<b>26</b>
Troubleshooting.....	26
Adjusting Zero-Stop Set Screw.....	27
<b>SECTION 7: PARTS.....</b>	<b>28</b>
T10687 Track Saw Parts Breakdown.....	28
T24872 Rail Track & T25094 Accessory Pack Parts Breakdown.....	30
<b>WARRANTY &amp; RETURNS.....</b>	<b>33</b>

# INTRODUCTION

---

---

## Manual Accuracy

---

---

We are proud to offer this document with your new Grizzly Model T10687 Track Saw! We've made every effort to be exact with the instructions, specifications, drawings, and photographs of the tool we used when writing this manual. However, sometimes we still make an occasional mistake.

Also, owing to our policy of continuous improvement, **your tool may not exactly match the manual**. If you find this to be the case, and the difference between the manual and tool leaves you in doubt, immediately call our technical support for updates or clarification.

For your convenience, we post all available documentation on our website at **www.grizzly.com**. Any updates to this document will be reflected on our website as soon as complete.

## Contact Info

---

---

We stand behind our machines. If you have any questions or need help, use the information below to contact us. Before contacting, please get the serial number and manufacture date of your machine. This will help us help you faster.

Grizzly Technical Support  
1203 Lycoming Mall Circle  
Muncy, PA 17756  
Phone: (570) 546-9663  
Email: techsupport@grizzly.com

We want your feedback on this manual. What did you like about it? Where could it be improved? Please take a few minutes to give us feedback.

Grizzly Documentation Manager  
P.O. Box 2069  
Bellingham, WA 98227-2069  
Email: manuals@grizzly.com

### CAUTION

**No list of safety guidelines can be complete. Every shop environment is different. Always consider safety first, as it applies to your individual working conditions. Use this and other machinery with caution and respect. Failure to do so could result in serious personal injury, damage to equipment or poor work results.**

# Glossary Of Terms

---

The following is a list of common definitions, terms and phrases used throughout this manual as they relate to this track saw and woodworking in general. Become familiar with these terms for assembling, adjusting or operating this machine. Your safety is **VERY** important to us at Grizzly!

**Arbor:** Metal shaft extending from the drive mechanism, to which saw blade is mounted. The blade is held in place on the arbor using a special arbor bolt and arbor washer.

**Bevel Edge Cut:** Tilting the saw blade to an angle between 0° and 45° to cut a beveled edge onto a workpiece.

**Blade Guard:** Metal or plastic safety device that encases the saw blade. Its function is to prevent the operator from coming into contact with the saw blade.

**Kerf:** The resulting cut or gap in the workpiece after the saw blade passes through during a cutting operation.

**Kickback:** An event in which the tool is propelled back towards the operator at a high rate of speed.

**Parallel:** Being an equal distance apart at every point along two given lines or planes. i.e. the rip fence face is parallel to the face of the saw blade.

**Perpendicular:** Lines or planes that intersect and form right angles. I.e. the blade is perpendicular to the table surface.

**Riving knife:** Metal plate located behind the blade. It maintains the kerf opening in the wood when performing a cutting operation.

**Straightedge:** A tool used to check the flatness, parallelism, or consistency of a surface(s).

**Through Cut:** A sawing operation in which the workpiece is completely sawn through.

**Rip Cut:** Cutting operation in which the rip fence is used to cut with the grain, or across the widest width of the workpiece.

**Plunge Cut:** A sawing operation in which the cut is started above the workpiece; the blade engages the workpiece by "plunging" down at the beginning of the cut, and advances once the blade cuts through the workpiece.



# Features and Controls

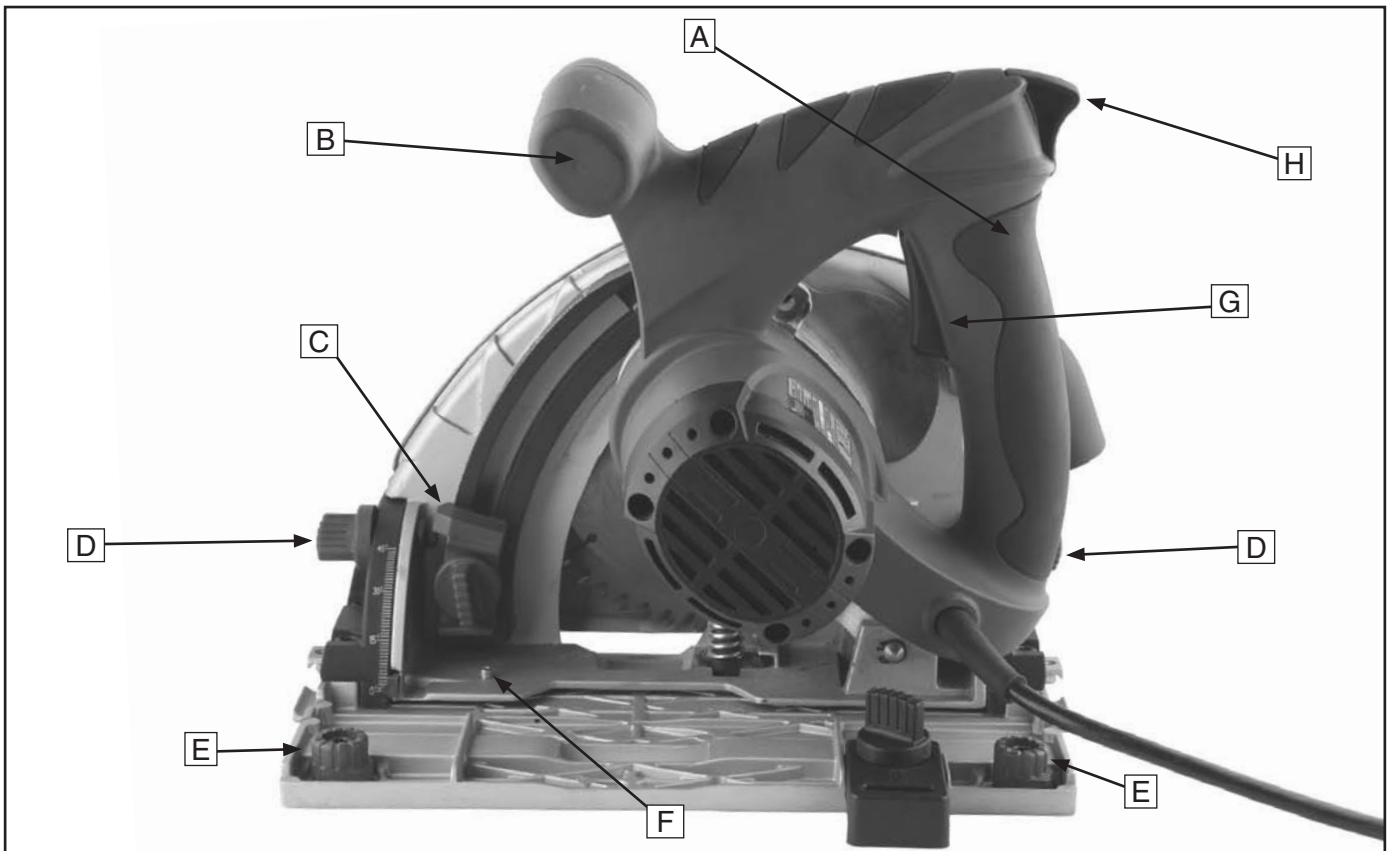

- A. Primary Handle:** Used to steady the saw when plunging and to advance its position on the workpiece/rail track.
- B. Secondary Handle:** Used to lower saw blade into workpiece once the plunge release and **ON/OFF** trigger have been pulled.
- C. Depth Stop & Lock Knob:** Sets the maximum depth at which the saw blade will enter the workpiece.
- D. Bevel Gauge & Lock Knob (Front & Rear):** Sets the angle (up to 45°) at which the saw blade will cut into the workpiece and locks it into place.
- E. Rail Adjustment Knobs:** Allows for adjustment of play in how saw slides along guide rail track to ensure accurate cuts.
- F. Zero-Stop Set Screw:** Fine-tunes the zero-stop point for calibrating the bevel gauge.
- G. ON/OFF Trigger:** Starts/stops the saw blade rotation and motor.
- H. Plunge Release:** Allows saw blade to pivot down and plunge into workpiece.



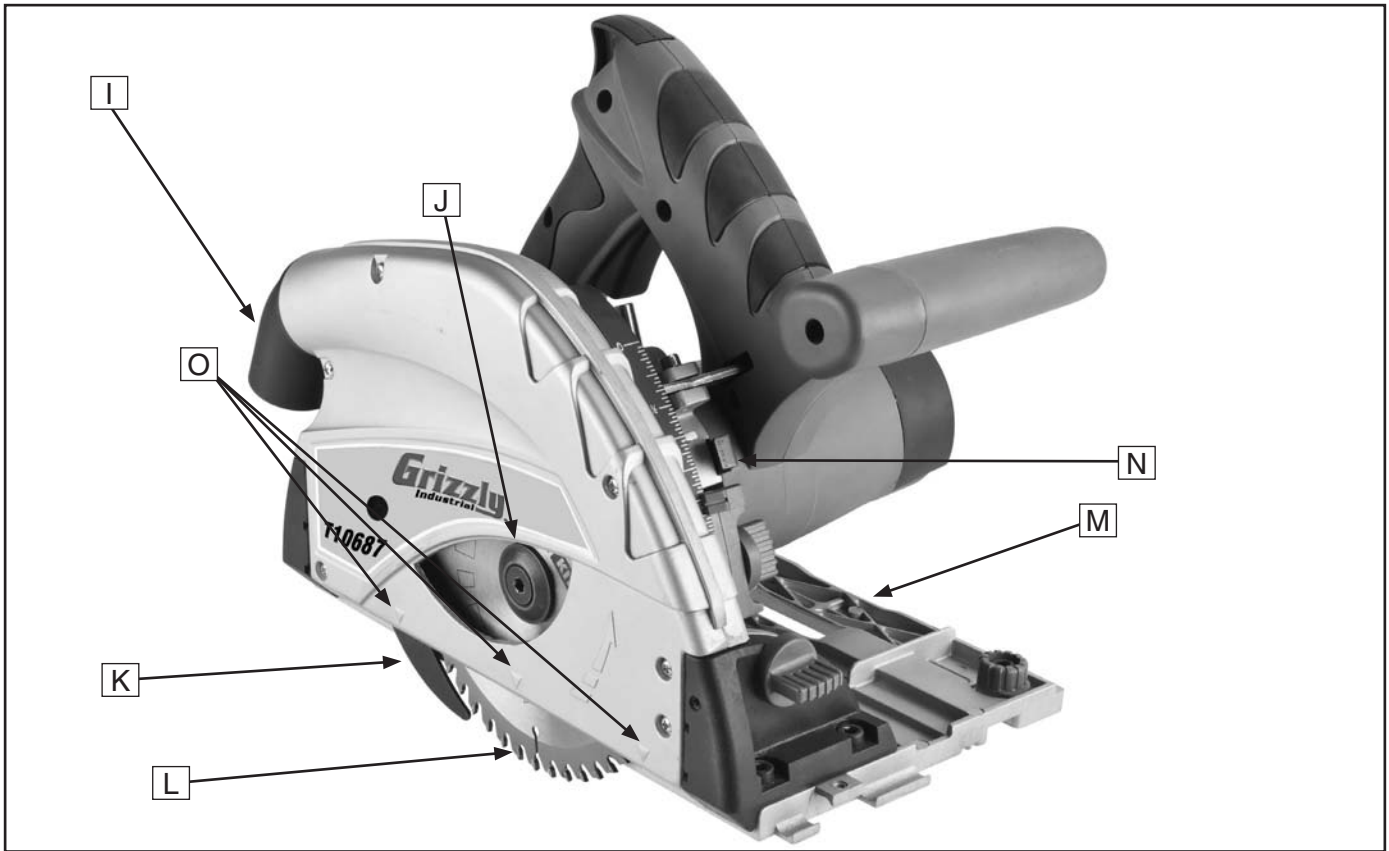

- I. Dust Collection Port:** 1½" port for connection to a dust collection system or shop vacuum (not included).

**J. Arbor Bolt:** Holds saw blade in place on the 20mm arbor. Remove it to change blades.

**K. Spring-Loaded Riving Knife:** Lowers into kerf behind blade to reduce risk of binding or pinching that causes kickback. Spring-loaded operation allows riving knife to work with plunge cuts. Also provides limited protection against accidental blade contact if kickback occurs.

**L. Saw Blade:** This saw is designed for a blade that has a 160mm diameter, a 20mm arbor, and is 2.2mm thick. A 48-tooth, carbide-tipped blade is included.
- M. Base Plate:** Can be attached to the accompanying rail track or placed directly on the workpiece if track is not used.

**N. Blade Lock:** Prevents the blade from rotating when changing blades.

**O. Cutting Indicator Arrows:** Three embossed indicator arrows, indicating maximum blade reach for the front and rear, as well as the center point of the blade.





# MACHINE DATA SHEET

© Grizzly Industrial, Inc. • Customer Service: (800) 523-4777 • Tech Support: (570) 546-9663

## MODEL T10687 TRACK SAW

### Product Dimensions:

Weight ..... 11 lbs.  
Width (side-to-side)/Depth (front-to-back)/Height ..... 13<sup>3</sup>/<sub>8</sub>" x 10<sup>1</sup>/<sub>4</sub>" x 9<sup>1</sup>/<sub>2</sub>"

### Shipping Dimensions:

Type ..... Cardboard Box  
Content ..... Machine  
Weight ..... 16 lbs.  
Width/Depth/Height ..... 13" x 10<sup>5</sup>/<sub>8</sub>" x 9<sup>1</sup>/<sub>4</sub>"

### Electrical:

Switch ..... Trigger with Safety Latch  
Cord Length ..... 6 ft.  
Cord Gauge ..... 18 AWG  
Plug Type Included ..... NEMA 1-15 Two-Prong Polarized

### Motor:

Type ..... Universal  
Horsepower ..... 1.1 KW  
Voltage ..... 120V  
Phase ..... Single-Phase  
Amps ..... 9A  
Speed ..... 5500 RPM  
Cycle ..... 60 Hz

### Main Specifications:

#### Blade Specifications

Blade Diameter ..... 160mm (6<sup>1</sup>/<sub>4</sub>")  
Blade Tilt ..... 0°-45°  
Arbor Size ..... 20mm  
Arbor Speed ..... 5500 RPM  
Blade Rim Speed ..... 9070 FPM

#### Cutting Capacities

Maximum Depth of Cut at 90° (without rail track) ..... 2<sup>5</sup>/<sub>32</sub>"  
Maximum Depth of Cut at 45° (without rail track) ..... 1<sup>5</sup>/<sub>8</sub>"  
Maximum Depth of Cut at 90° (with rail track) ..... 1<sup>31</sup>/<sub>32</sub>"  
Maximum Depth of Cut at 45° (with rail track) ..... 1<sup>7</sup>/<sub>16</sub>"

#### Construction

Saw Construction ..... Aluminum and Engineered Plastic  
Hand Grips ..... Heavy-Duty Rubberized  
Rail Track ..... Aluminium  
Number of Dust Ports ..... 1  
Dust Port Size ..... 1<sup>1</sup>/<sub>2</sub>"





**Other Specifications:**

Country Of Origin ..... China  
Warranty ..... 1 Year  
Serial Number Location ..... ID Label on Motor Housing  
Assembly Time ..... 10 Minutes

**Features:**

Anti-Kickback Design with Spring-Loaded Riving Knife  
Low-Profile Blade Guard for Cuts as Close as 5/8" from Wall  
1 1/2" Dust Port for Efficient Dust Collection  
Versatile—Saw can be Used With or Without Track  
Precision Depth Control Scale in 1/32" Increments  
48 Tooth Carbide Tip Blade Included

**Optional Accessories:**

T24872 55" Rail Track  
T25094 Accessories Pack (Includes rail connector, (2) F-clamps, stop, and stabilizer)  
T25331 48-Tooth Replacement Blade



# SECTION 1: SAFETY

## For Your Own Safety, Read Instruction Manual Before Operating this Power Tool

The purpose of safety symbols is to attract your attention to possible hazardous conditions. This manual uses a series of symbols and signal words intended to convey the level of importance of the safety messages. The progression of symbols is described below. Remember that safety messages by themselves do not eliminate danger and are not a substitute for proper accident prevention measures. Always use common sense and good judgment.

 **DANGER** Indicates an imminently hazardous situation which, if not avoided, **WILL** result in death or serious injury.

 **WARNING** Indicates a potentially hazardous situation which, if not avoided, **COULD** result in death or serious injury.

 **CAUTION** Indicates a potentially hazardous situation which, if not avoided, **MAY** result in minor or moderate injury. It may also be used to alert against unsafe practices.

**NOTICE** This symbol is used to alert the user to useful information about proper operation of the machine.

## Safety Instructions for Power Tools

### **WARNING**

**OWNER'S MANUAL.** Read and understand this owner's manual **BEFORE** using machine.

**TRAINED OPERATORS ONLY.** Untrained operators have a higher risk of being hurt or killed. Only allow trained/supervised people to use this power tool. When tool is not being used, disconnect power, and store in out-of-reach location to prevent unauthorized use—especially around children. Make workshop kid proof!

**DANGEROUS ENVIRONMENTS.** Do not use tools in areas that are wet, cluttered, or have poor lighting. Operating tools in these areas greatly increases risk of accidents and injury.

**MENTAL ALERTNESS REQUIRED.** Full mental alertness is required for safe operation of power tools. Never operate under the influence of drugs or alcohol, when tired, or when distracted.

**DISCONNECT POWER FIRST.** Always disconnect tool from power supply **BEFORE** making adjustments, changing tooling, or servicing machine. This prevents an injury risk from unintended startup or contact with live electrical components.

**EYE PROTECTION.** Always wear ANSI-approved safety glasses or a face shield when operating or observing machinery to reduce the risk of eye injury or blindness from flying particles. Everyday eyeglasses are not approved safety glasses.

**ELECTRICAL SAFETY.** Tool plug must match outlet. Double-insulated tools have a polarized plug (one blade is wider than the other), which must be plugged into a polarized outlet. Never modify plug. Do not use adapter for grounded tools. Use a ground fault circuit interrupter if operation is unavoidable in damp locations. Avoid touching grounded surfaces when operating tool.



# WARNING

**WEARING PROPER APPAREL.** Do not wear clothing, apparel or jewelry that can become entangled in moving parts. Always tie back or cover long hair. Wear non-slip footwear to avoid accidental slips, which could cause loss of workpiece control. Wear hard hat as needed.

**HAZARDOUS DUST.** Dust created while using tools may cause cancer, birth defects, or long-term respiratory damage. Be aware of dust hazards associated with each workpiece material, always wear a NIOSH-approved respirator, and connect tool to an appropriate dust collection device to reduce your risk.

**HEARING PROTECTION.** Always wear hearing protection when operating or observing loud machinery. Extended exposure to this noise without hearing protection can cause permanent hearing loss.

**REMOVE ADJUSTING TOOLS.** Never leave adjustment tools, chuck keys, wrenches, etc. in or on tool—especially near moving parts. Verify removal before starting!

**INTENDED USAGE.** Only use tool for its intended purpose. Never modify or alter tool for a purpose not intended by the manufacturer or serious injury or death may result!

**AWKWARD POSITIONS.** Keep proper footing and balance at all times when operating tool. Do not overreach! Avoid awkward hand positions that make tool control difficult or increase the risk of accidental injury.

**SAFE HANDLING.** Firmly grip tool. To avoid accidental firing, do not keep finger on switch or trigger while carrying.

**SECURING WORKPIECE.** When required, use clamps or vises to secure workpiece. A secured workpiece protects hands and frees both of them to operate the tool.

**GUARDS & COVERS.** Guards and covers reduce accidental contact with moving parts or flying debris. Make sure they are properly installed, undamaged, and working correctly.

**CHILDREN & BYSTANDERS.** Keep children and bystanders at a safe distance from the work area. Stop using machine if they become a distraction.

**FORCING TOOLS.** Use the right tool for the job, and do not force it. It will do the job safer and better at the rate for which it was designed.

**USE RECOMMENDED ACCESSORIES.** Consult this owner's manual or the manufacturer for recommended accessories. Using improper accessories will increase the risk of serious injury.

**MAINTAIN WITH CARE.** Keep cutting tool edges sharp and clean. Follow all maintenance instructions and lubrication schedules to keep tool in good working condition. A tool that is improperly maintained could malfunction, leading to serious personal injury or death. Only have tool serviced by qualified service-personnel using matching replacement parts.

**CHECK DAMAGED PARTS.** Regularly inspect tool for any condition that may affect safe operation. Immediately repair or replace damaged or mis-adjusted parts before operating tool.

**MAINTAIN POWER CORDS.** When disconnecting cord-connected tools from power, grab and pull the plug—NOT the cord. Carrying or pulling the cord may damage wires inside. Do not handle cord/plug with wet hands. Avoid cord damage by keeping it away from heated surfaces, high traffic areas, harsh chemicals, sharp edges, moving parts, and wet/damp locations. Damaged cords increase risk of electrocution.

**UNATTENDED OPERATION.** Never leave tool running while unattended. Turn tool off and ensure all moving parts completely stop before walking away.

**EXPERIENCING DIFFICULTIES.** If at any time you experience difficulties performing the intended operation, stop using the machine! Contact our Technical Support at (570) 546-9663.



# WARNING

## Additional Safety for Circular Saws

**MAIN INJURY HAZARDS:** Death, amputation, or lacerations from contacting the spinning saw blade; blindness or eye injury from flying workpiece chips or tramp metals. To minimize your risk of these hazards, always heed the following warning information:

**BLADE MAINTENANCE.** Always ensure that the saw blades are sharp, undamaged, and tightly attached before each use. Only use blades that meet the specifications listed on the data sheet.

**RECOMMENDED ACCESSORIES.** Only use appropriate blades for this saw. Do not use blades with different diameters or arbor hole shapes/sizes, as they will not rotate concentrically and may damage the saw and throw blade fragments with deadly force.

**RIVING KNIFE.** Make sure the riving knife is thicker than the saw blade but thinner than the blade teeth. The riving knife must be present in the kerf and properly adjusted with the blade to be effective.

**GUARDS.** Ensure guards are in place and operating correctly before each cut. Repair or replace guard if it is damaged.

**PHYSICAL SAFETY.** Keep hand and fingers clear of cutting path at all times. Never reach under workpiece near blade, and do not perform a cut while supporting workpiece with one hand or balancing it on a leg or any other body part.

**CUTTING DEPTH.** Set the cutting depth so the blade protrudes no more than  $\frac{1}{8}$ " beyond the backside or bottom of the workpiece.

**STRAIGHT CUTS.** Only make straight cuts. Always use a guide to reduce risk of binding and kickback. Do not make freehand cuts!

**STOPPING AND RESTARTING CUTS.** Allow blade to reach full speed before cutting. Complete all cuts when possible. If a cut must be interrupted, let blade come to a complete stop before removing saw. Before resuming, place blade in center of kerf and verify teeth do not contact workpiece.

**CUTTING CORRECT MATERIAL.** Use the correct blade for the type of material being cut. Do not use this saw for cutting logs, roots, or trimming shrubs and trees. Do not cut warped, twisted, or cupped workpieces.

**PLUNGE CUTS.** To decrease risk of kickback, do not allow the saw base to shift while performing beveled plunge cuts. Before making blind plunge cuts, verify the cutting path is clear of obstructions (electrical wires, gas lines, plumbing, metal or stone, etc.) to reduce the risk of explosion, fire, electrocution, property damage, or kickback. Disconnect fuses or circuit breakers, and shut off nearby water and gas lines if cutting nearby.

**WORKPIECE SUPPORT.** Properly support all workpieces and cutoffs to reduce risk of binding and kickback. Place supports under both sides of the cut line.

**WORKPIECE CLEARANCE.** Ensure adequate clearance under workpiece to reduce risk of blade contacting materials (concrete, rocks, metal, etc.) that could damage it and cause it to fly apart.



# Understanding Kickback

Kickback is a sudden and unexpected expulsion of the saw from the workpiece, which can violently propel the saw back toward the operator, resulting in accidental blade contact or impact injury.

Kickback is caused when the saw blade becomes misaligned, pinched, bound, or comes in contact with a material it is unable to cut. When kickback occurs, the saw blade becomes immediately immobile. The force produced by the motor is diverted from the blade and transferred to the saw, pushing it up and away from the workpiece and potentially toward the operator.

The lack of warning and high risk of injury from kickback makes it extremely important to: (1) reduce the risk of kickback, and (2) protect yourself in case it does occur.

## Preventing Kickback

**Take these precautions to help prevent the most common causes of kickback:**

- Hold the saw firmly with both hands and position arms to help resist kickback forces. Always stand to one side of the saw when operating—never directly behind it. When kickback does occur, it will eject the saw back toward the operator.
- Ensure the workpiece remains level and immobile throughout your cut. Do not cut warped, cupped, or twisted workpieces. Minimize the chances of the workpiece rocking, rotating, or shifting, which could bind the blade and allow kickback to occur. Clamp workpiece in place if necessary.
- Support large panels, making sure supports are positioned under both sides of the cutting line.

- Allow blade to reach full speed before starting the cut.
- To help prevent the blade from binding in the workpiece: (1) keep cuts straight, (2) maintain a consistent depth and angle throughout cut, (3) provide proper workpiece support on both sides of the cut (see **Figures 1–2**).

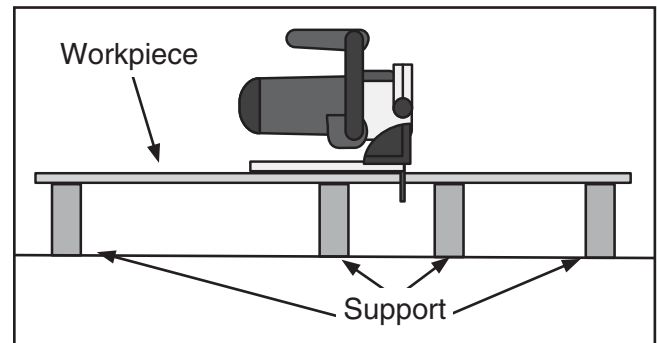

**Figure 1.** Cutting with proper workpiece support.

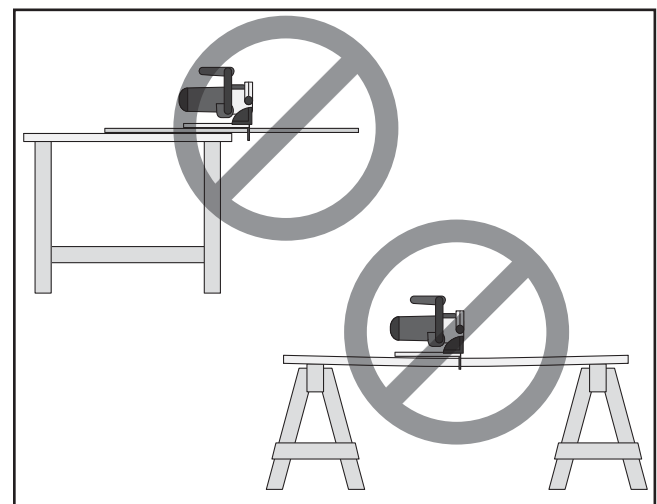

**Figure 2.** Cutting with improper support.

- Follow cuts through to completion whenever possible. If a cut must be stopped before completion or the blade begins to bind, release the ON/OFF trigger and hold the saw motionless while the blade comes to a complete stop before removing it from the workpiece. When resuming the cut, center your blade in the kerf and ensure that the teeth are not touching the workpiece.
- Only use sharp, clean, undamaged blades. Dull blades create much more friction and resistance while cutting, which greatly increases the risk of kickback.



# SECTION 2: POWER SUPPLY

## Availability

Before installing the machine, consider the availability and proximity of the required power supply circuit. If an existing circuit does not meet the requirements for this machine, a new circuit must be installed. To minimize the risk of electrocution, fire, or equipment damage, installation work and electrical wiring must be done by an electrician or qualified service personnel in accordance with all applicable codes and standards.

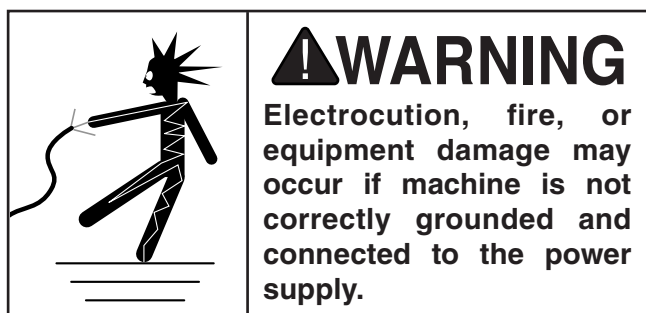

## Full-Load Current Rating

The full-load current rating is the amperage a machine draws at 100% of the rated output power. On machines with multiple motors, this is the amperage drawn by the largest motor or sum of all motors and electrical devices that might operate at one time during normal operations.

### Full-Load Current Rating at 120V ..... 9 Amps

The full-load current is not the maximum amount of amps that the machine will draw. If the machine is overloaded, it will draw additional amps beyond the full-load rating.

If the machine is overloaded for a sufficient length of time, damage, overheating, or fire may result—especially if connected to an undersized circuit. To reduce the risk of these hazards, avoid overloading the machine during operation and make sure it is connected to a power supply circuit that meets the requirements in the following section.

## **! WARNING**

**Serious injury could occur if you connect the machine to power before completing the setup process. DO NOT connect to power until instructed later in this manual.**

## 120V Circuit Requirements

This machine is prewired to operate on a power supply circuit that has a verified ground and meets the following requirements:

Voltage..... 120V  
Cycle.....60 Hz  
Phase..... Single-Phase  
Power Supply Circuit ..... 15 Amps

A power supply circuit includes all electrical equipment between the breaker box or fuse panel in the building and the machine. The power supply circuit used for this machine must be sized to safely handle the full-load current drawn from the machine for an extended period of time. (If this machine is connected to a circuit protected by fuses, use a time delay fuse marked D.)

## **! CAUTION**

**For your own safety and protection of property, consult an electrician if you are unsure about wiring practices or electrical codes in your area.**

**Note:** *The circuit requirements listed in this manual apply to a dedicated circuit—where only one machine will be running at a time. If this machine will be connected to a shared circuit where multiple machines will be running at the same time, consult a qualified electrician to ensure that the circuit is properly sized for safe operation.*



## Polarized Plug

This tool is double-insulated and therefore does not have a grounding wire or plug. The two-pronged, NEMA 1-15 plug has a polarized end; this means that one prong (the neutral connector) is wider than the other (the hot connector). Polarized plugs must be used only with polarized receptacles. Do not attempt to plug this tool into a non-polarized receptacle. If a polarized receptacle is not available, a qualified electrical technician will have to install one before the saw can be plugged in.

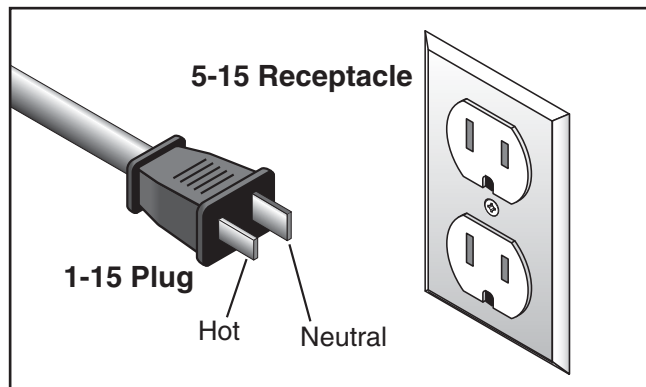

Figure 3. Typical 1-15 plug and receptacle.

## Extension Cords

When using extension cords, make sure the cords are rated for outdoor use. Outdoor use cords are marked with a "W-A" or a "W" to signify their rating. Always check to make sure that the extension cords are in good working order and free of any type of damage, such as exposed wires, cuts, creased bends, or missing prongs.

Extension cords cause voltage drop, which may damage electrical components and shorten motor life. Voltage drop increases as the extension cord size gets longer and the gauge size gets smaller (higher gauge numbers indicate smaller sizes). When using extension cords, always choose the shortest cord possible, with the greatest-sized gauge.

Below is a list of minimum gauge sizes needed for running this tool at different lengths:

25 Feet.....	16AWG
50 Feet.....	14AWG
100 Feet.....	12AWG
Over 100 Feet.....	Not Recommended



# SECTION 3: SETUP

## Unpacking

Your saw was carefully packaged for safe transportation. Remove the packaging materials from around your saw and inspect it. If you discover the machine is damaged, please immediately call Customer Service at (570) 546-9663 for advice.

Save the containers and all packing materials for possible inspection by the carrier or its agent. Otherwise, filing a freight claim can be difficult.

When you are completely satisfied with the condition of your shipment, inventory the contents.

If any non-proprietary parts are missing (e.g., a nut or a washer), we will gladly replace them; or for the sake of expediency, replacements can be obtained at your local hardware store.

	<p><b>⚠ WARNING</b> <b>SUFFOCATION HAZARD!</b> Keep children and pets away from plastic bags or packing materials shipped with this machine. Discard immediately.</p>
---	---

<p><b>NOTICE</b> If you cannot find an item on this list, carefully check the machine and the packaging materials. Some of these items may be pre-installed for shipping or become misplaced during unpacking.</p>
--

## Included Inventory

### T10687 Included Inventory (Figures 4)

- A. Track Saw..... 1
- B. Blade 48T..... 1
- C. Hex Wrench 5mm (not shown)..... 1

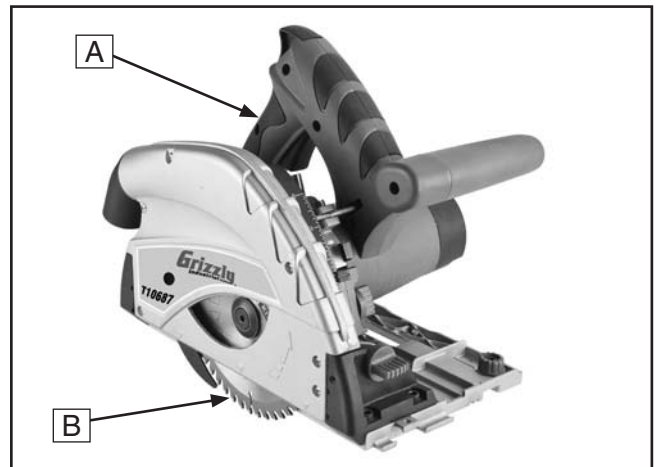

Figure 4. Track saw and blade.

## Optional Accessories

The following accessories are available to help you get the most out of your T10687 Track Saw.

### T24872—55" Guide Rail

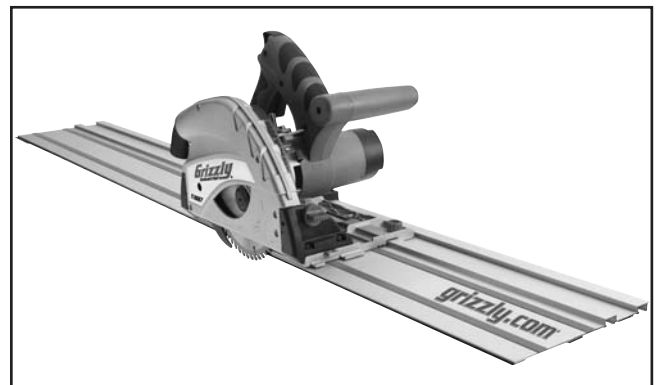

Figure 5. Track saw on T24872 55" Guide Rail.





## T25094—Accessories Pack for T24872 Rail

- A. Rail Track Connector..... 1
- B. Stabilizer..... 1
- C. Adjustable Stop ..... 1
- D. F-Clamps..... 2

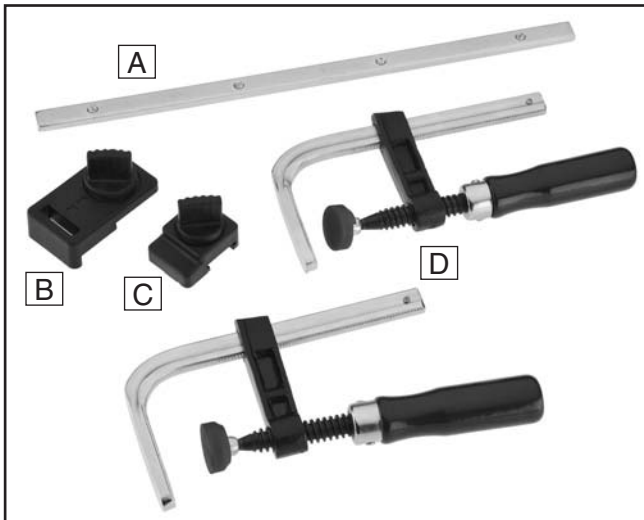

Figure 6. T25094 Accessories Pack.

## T25331—48-Tooth Blade for T10687 Saw



Figure 7. T25331 48-Tooth Blade.

# Dust Collection

## ⚠ CAUTION

This machine creates substantial amounts of dust during operation. Breathing airborne dust on a regular basis can result in permanent respiratory illness. Reduce your risk by wearing a respirator and capturing the dust with a dust collection system.

### Recommended CFM at Dust Port: 100 CFM

Do not confuse this CFM recommendation with the rating of the dust collector. To determine the CFM at the dust port, you must consider these variables: (1) CFM rating of the dust collector, (2) hose type and length between the dust collector and the machine, (3) number of branches or wyes, and (4) amount of other open lines throughout the system. Explaining how to calculate these variables is beyond the scope of this manual. Consult an expert or purchase a good dust collection "how-to" book.

### To connect a dust collection hose:

1. Fit the 1½" dust hose over the dust port (see **Figure 8**), and secure in place with a hose clamp.
2. Tug the hose to make sure it does not come off. **Note:** A tight fit is necessary for proper performance.

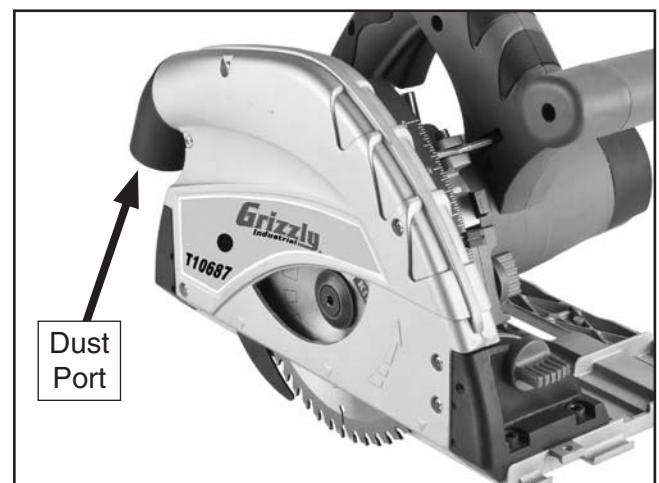

Figure 8. Dust port location.



# SECTION 4: OPERATIONS

## Using the Saw

The T10687 Track Saw is designed to be used with wood and wood-based material. This tool should not be used to cut ferrous metals (steel, cast iron, etc.), glass, aluminum, plastics, ceramics, tile, drywall, cementitious backer board, carpet, foam, or any type of food.

## Blade Selection

Always use sharp blades and select the correct blade for the material being cut. The resulting cut will be cleaner and there will be less stress on the machine. Always inspect saw blades closely before installation, and never use saw blades with bent or missing teeth, or that appear damaged in any way. The T10687 comes with a 48-tooth carbide-tipped blade that will effectively handle most wood and wood-like materials.

### Blade Requirements:

- 160mm diameter
- 20mm round arbor bore

Keep in mind that blade teeth should never be thinner than the riving knife; otherwise the riving knife could get stuck in the kerf.

## Changing Blades

### **⚠️ WARNING**

**Severe lacerations, amputation, or death can occur if blade changing/adjustment is attempted while saw is connected to power. Always unplug saw before changing or making any adjustments to blade or riving knife, or performing any maintenance to the saw that would require direct physical contact with the blade.**

When changing saw blades, always keep the saw in an upright position. Position the saw along the edge of a workbench or table, so that the blade can be lowered safely down below the surface edge of the workspace while the saw remains upright.

### To change the blade:

1. DISCONNECT SAW FROM POWER!
2. Engage the plunge release and lower the blade down far enough to expose the arbor bolt. Push the blade lock (see **Figure 9**) and rotate the arbor bolt with a 5mm hex wrench until the blade locks in place.

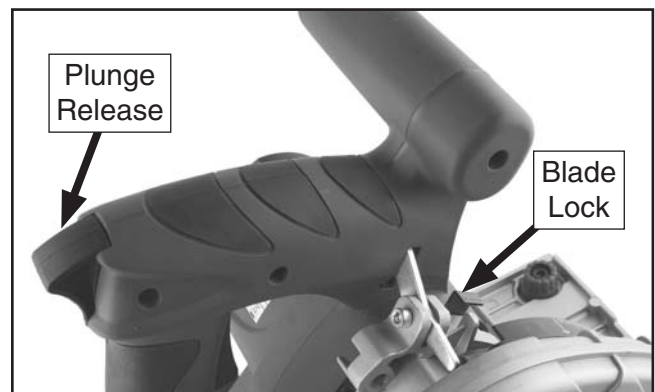

**Figure 9.** T10687 top view.



## **⚠ CAUTION**

Even worn saw blades can be extremely sharp and dangerous to handle. To avoid injury, wear protective gloves when handling circular blades.

3. With your free hand, turn the arbor bolt counterclockwise with a 5mm hex wrench to loosen it, as shown in **Figure 10**.



**Figure 10.** Loosening arbor bolt.

4. Once the arbor bolt has been loosened, use your fingers to carefully remove it, along with the arbor washer, then guide the blade down and out of the saw.
5. When ready to insert a new blade, lower the saw back down so that the arbor flange is visible. Insert a new blade into the saw. Align the center of the blade over the arbor flange and let it rest there.

6. Make sure grooves of the arbor washer are correctly lined up with the flange. Thread the arbor bolt and washer into place with your free hand. The correct order of installation is shown below in **Figure 11** for your reference.

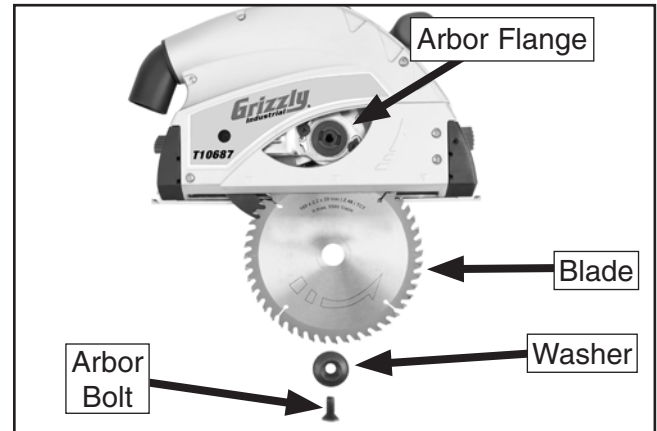

**Figure 11.** Saw blade and blade-fastening components.

7. Engage the blade lock to keep the arbor flange steady, and tighten the arbor bolt firmly using a 5mm hex wrench.



# Riving Knife Adjustment

The riving knife must be properly aligned with the blade and positioned the correct distance away from it to work effectively.

As with changing the blade, always keep the saw upright, and position the saw along the edge of a workbench or table so that the blade and riving knife can be lowered safely down below the surface edge.

## To adjust the riving knife:

1. Engage the plunge release and lower the blade down until the riving knife lock is accessible through the port hole (see **Figure 12**).



**Figure 12.** Location of riving knife port hole.

2. Using a 5mm hex wrench, loosen the riving knife lock, as shown in **Figure 13**.



**Figure 13.** Loosening the riving knife lock.

3. Position the riving knife  $\frac{3}{32}$ "– $\frac{1}{8}$ " (2-3mm) away from the saw blade teeth, and ensure that it is just above the lowest part of the blade.
4. Retighten the riving knife lock after making the adjustment.
5. Use a straightedge to verify that the riving knife is properly aligned with the blade.

—If the two are misaligned, then check that your blade thickness is not less than the thickness of the riving knife.

—If the thickness is correct, then remove the riving knife and check for straightness. NEVER use a warped or damaged riving knife when making a cut; doing so could cause kickback.



# Setting Cutting Depth

Cutting depth should always be set at just past the bottom of the workpiece. The best way to accurately set the depth is to position the saw along one edge of the workpiece so that the blade extends below the workpiece (similar to the process of allowing the blade to extend when being changed). Once the blade is extended, determine the necessary depth by allowing the blade to extend roughly  $\frac{1}{8}$ " beyond the bottom of the workpiece, as shown in **Figure 14**.

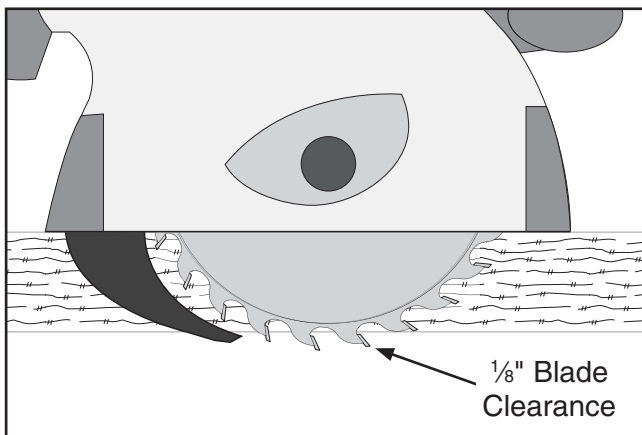

**Figure 14.** Setting saw depth by aligning blade with the workpiece.

To set the cutting depth:

1. Loosen the lock knob and adjust the depth stop along the scale to the maximum depth desired for the cut (see **Figure 15**).

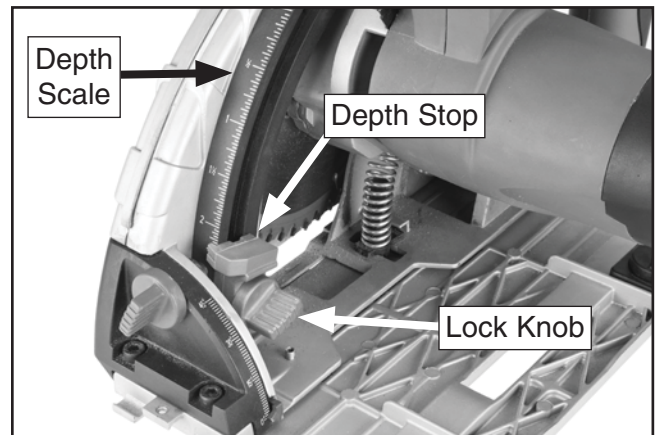

**Figure 15.** Depth-setting components.

2. Retighten the lock knob. The saw blade will now extend only to that set point.

**Note:** The cutting depth shown on the scale is the depth *WITHOUT* the rail track. The track adds an additional  $\frac{3}{16}$ " thickness to the cutting point.



# Setting Cutting Angle

The cutting angle of the blade can be set with the bevel gauge. Cutting angles can be set from 90°–45°.

## To set the cutting angle:

1. Loosen the front and rear bevel gauge knobs (see **Figure 16**).

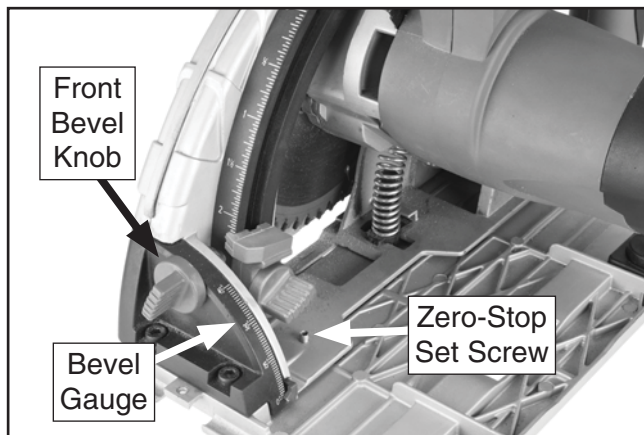

**Figure 16.** Angle-setting components.

2. While holding the base plate, carefully pull the body of the saw out to the desired angle. (Refer to the angular scale along the side of the bevel gauge.)
3. Tighten the front and rear bevel gauge knobs.

# Making Straight Cuts



There are generally two types of cuts made with this saw—straight cuts and plunge cuts.

Straight cuts are made with the blade already extended, with the cut beginning on one edge of the workpiece and ending on the opposite side. These cuts work well for cutting objects into separate pieces and for straight-lining rough lumber.

## To make basic straight cuts:

1. Set the depth of cut (as described in the **Setting Cutting Depth** section on **Page 19**).
2. Position the front of the saw onto the workpiece, leaving enough room for the blade to fully extend from the bottom without coming into contact with the workpiece, as shown in **Figure 17**.

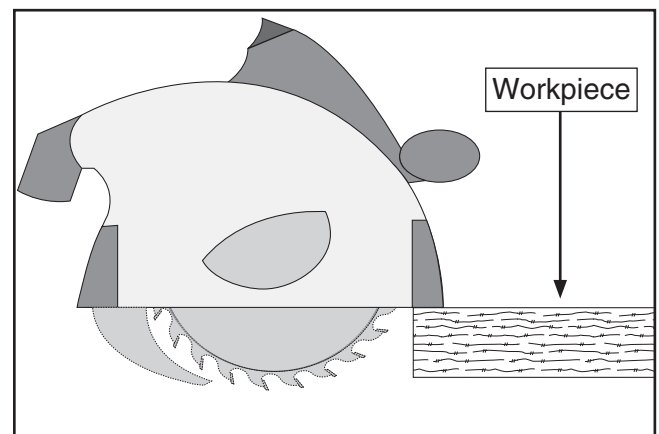

**Figure 17.** Positioning the saw onto the workpiece for a straight cut.



3. Hold the saw firmly with one hand on each handle, as shown in **Figure 18**.

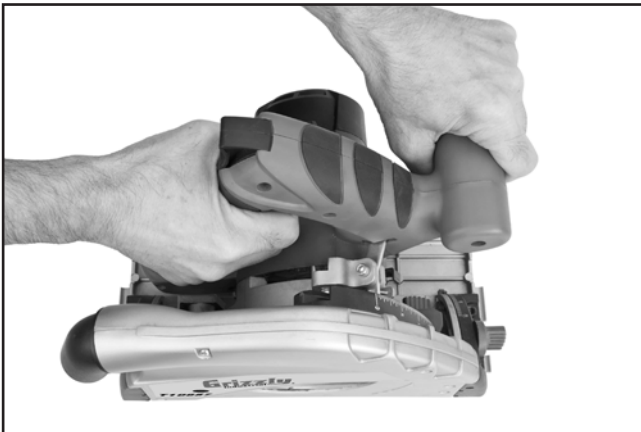

**Figure 18.** Proper hand positions.

## **! WARNING**

Keep fingers and hands away from the saw blade and out of blade path during operation. Use clamps to hold the workpiece in place if needed.

## **! CAUTION**

Let the saw reach full speed before contacting the workpiece. Doing so will reduce the risk of kickback, help provide the cleanest cut, and reduce stress on the saw motor.

4. Engage the plunge release and extend the blade. To activate the saw, pull the power trigger while holding the plunge release.

**Note:** *Holding the power trigger alone will not activate the saw. For power to be activated, both the plunge release and the power trigger must be pressed. After power has been activated, the plunge release can be disengaged.*

5. Move the saw forward over the workpiece in an even, steady motion.
6. When finished, release the power trigger and allow the blade to come to a complete stop. Return the saw to its upright position by lifting up on the handle, allowing the blade to retract and the saw to lock in place.

# Making Plunge Cuts

Plunge cuts are made by positioning the saw on the workpiece so that the blade begins cutting as soon as it is lowered. Plunge cuts work well for removing an area within the workpiece without sawing through the outer perimeter.

## **! WARNING**

Making blind plunge cuts without checking your cutting path for unseen objects could result in injury from kickback, electrocution, building damage or fire, gas explosions, or death. Whenever making a blind plunge cut into a standing structure (like a wall), always check the cutting path for hidden wires, nails, and other metal objects by thoroughly scanning the area with an electric stud finder or similar device. **NEVER** risk a blind plunge cut without first checking your cutting path.

## **! WARNING**

Whenever operating the saw in the vicinity of live wires, always wear insulated gloves. Avoid unintentionally grounding yourself when operating the saw by being in contact with electrically-conductive materials (metal pipes, appliances, etc.).

### To make plunge cuts:

1. Mark the desired start and stop cut-points on your workpiece.
2. Set the depth of cut (as described in the **Setting Cutting Depth** section on **Page 19**).



3. Align the start cut-point with the rear cutting indicator arrow (see **Figure 19**). This arrow marks the maximum rear cutting distance the blade will travel when fully extended.

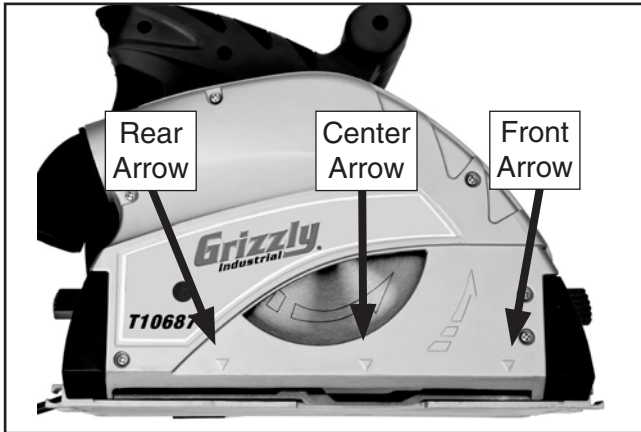

**Figure 19.** Cutting indicator arrows.

**Note:** The front and rear cutting indicator arrows are only accurate when the blade is fully extended. If the saw depth gauge is set, the maximum cutting distance will be less.

4. Engage the plunge release and lower the blade slightly, but without touching the workpiece.
5. To activate the saw, engage the power trigger while holding the plunge release.

**Note:** Holding the power trigger alone will not activate the saw. For power to be activated, both the plunge release and the power trigger must be pressed. After power has been activated, the plunge release can be disengaged.

## **! CAUTION**

Let the saw reach full speed before contacting the workpiece. Doing so will reduce the risk of kickback, help provide the cleanest cut, and reduce stress on the saw motor.

6. Lower the blade until the set cutting depth is reached. The blade and riving knife will descend into the workpiece, as shown in **Figure 20**. Move the saw forward in an even, steady motion. When the front indicator arrow reaches the stop point, the cut has been completed.



**Figure 20.** Plunge-action lowering for the cut.





# Using Rail Track

Using your saw with the rail track allows for quick and precise cuts with minimal setup time. Both straight cuts and plunge cuts can be made in conjunction with the rail track.

**Note:** *The bottom of the rail track includes an oversized rubber lip that serves as a splinter guard. The first time the track saw is used with the rail, the saw blade will cut the edge of that lip to provide a zero-clearance effect, which will help minimize splintering.*

## To set up the saw with the rail track:

1. Align the rail track along the workpiece. Use the right (flat) side of the rail track to plan the cut.
2. When satisfied with the position of the rail track, use F-clamps to secure it to the workpiece, as shown in **Figure 21**.

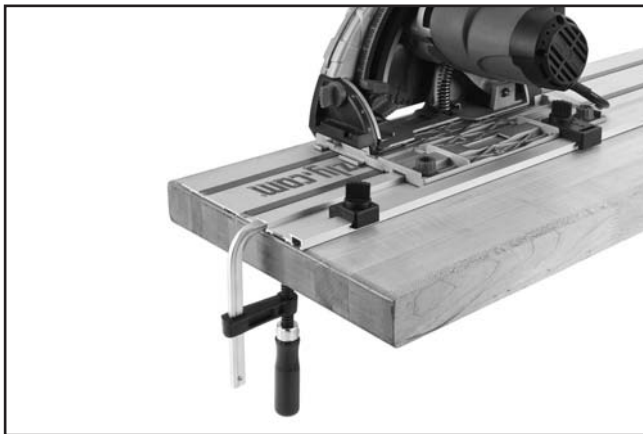

**Figure 21.** Rail track clamped to workpiece.

3. Place the saw onto the rail track so the blade engages the workpiece to the right of the rail.
4. Adjust the rail adjustment knobs to position the saw along the rail (see **Figure 22**). When the rail edge and saw cutting path both line up straight, the saw is properly set up with the rail track.

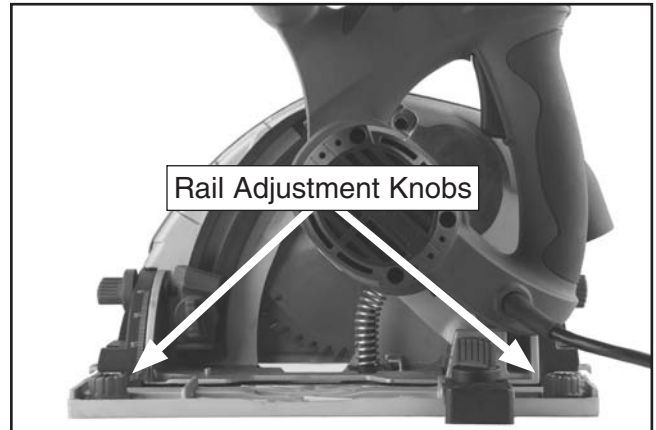

**Figure 22.** Location of rail adjustment knobs.

# Adding Rail Tracks

Additional rail tracks can be purchased and joined together with the rail track connector. To connect multiple tracks, insert the connector into the inner grooves of each rail track (see **Figure 23**). Flip the rail tracks over and slide the tracks together so that the connector is equally-distributed. Tighten the connector set screws into place with a hex wrench.

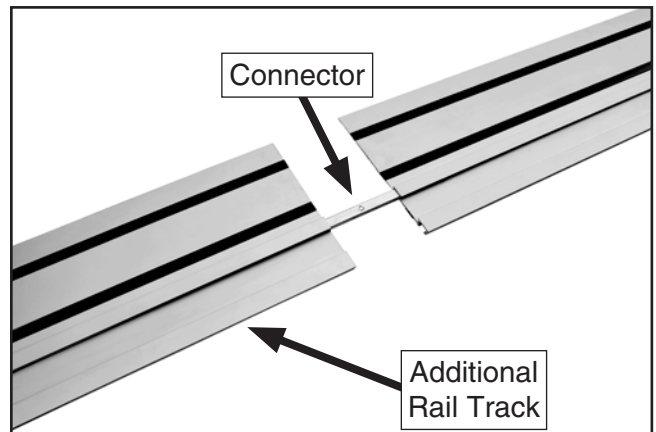
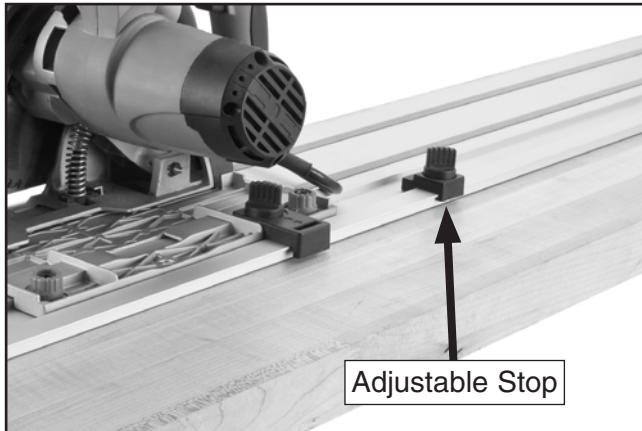

**Figure 23.** Joining two rail tracks.



# Using Adjustable Stop

The adjustable stop (see **Figure 24**) attaches to the rail track and is positioned in front of the saw body. The adjustable stop fits on the outer rail of the rail track and provides a stable stopping point along the rail track, which is especially useful when making plunge cuts.



**Figure 24.** Adjustable stop on rail track.

# Using the Stabilizer

The stabilizer (see **Figure 25**) clips the saw onto the rail track to help prevent the saw from accidentally derailing. The stabilizer is attached to the base plate.

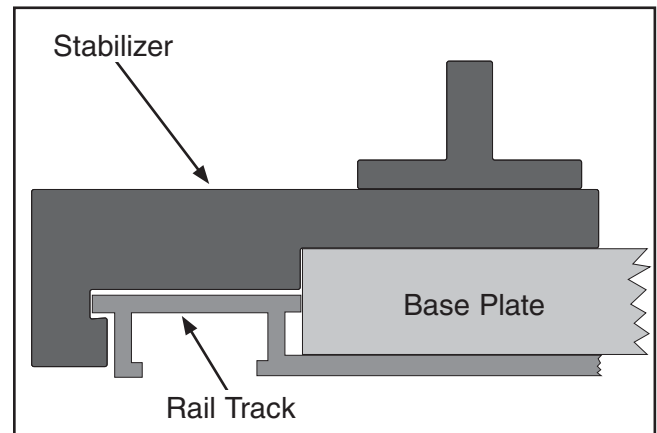

**Figure 25.** Stabilizer clipped over rail track.

To position the stabilizer against the rail track, loosen the thumb screw and adjust the outer lip of the stabilizer around the outside of the rail track, as shown in **Figure 26**. Retighten the thumb screw once the stabilizer lip is in place.

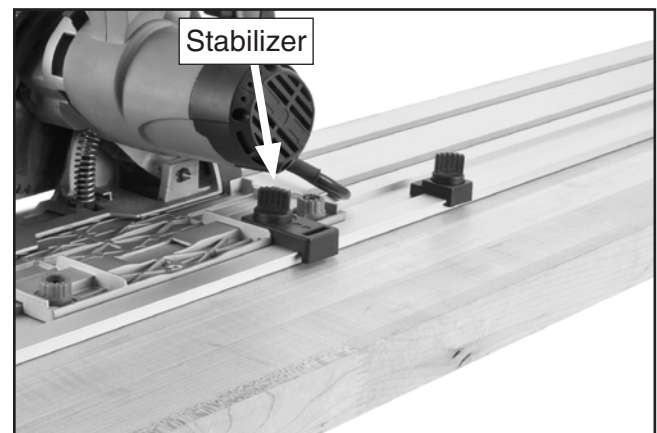

**Figure 26.** Stabilizer on rail track.

When not in use, remove the stabilizer from the saw base plate. The stabilizer rests slightly lower than the saw base plate and could affect the angle of the blade to the workpiece when not attached to the rail track.



# SECTION 5: MAINTENANCE

---

---

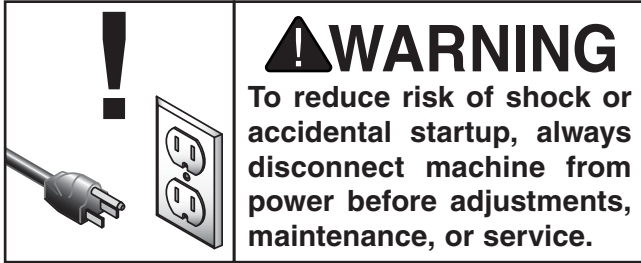

## Electrical

---

The electrical components of this saw are not user-serviceable. This product is double-insulated, which provides protection from electrical shock should a problem ever develop with grounding.

Great care must be taken whenever servicing double-insulated equipment to make certain repair does not destroy the insulated properties. Service should be performed only by or under the guidance of qualified service personnel.

## Cleaning

---

---

Cleaning the Model T10687 is relatively easy. Vacuum excess wood chips and sawdust, and wipe off the remaining dust with a dry cloth.

## Lubrication

---

---

All rotating parts within the saw are pre-lubricated and sealed. Do not attempt to lubricate the saw or saw blade. The saw requires dry conditions for proper use.

## Blade

---

---

Always check the saw blade for damage, dullness, or excessive wear before each use.



# SECTION 6: SERVICE

Review the troubleshooting and procedures in this section if a problem develops with your machine. If you need replacement parts or additional help with a procedure, call our Technical Support at (570) 546-9663.

**Note:** Please gather the serial number and manufacture date of your machine before calling.

## Troubleshooting

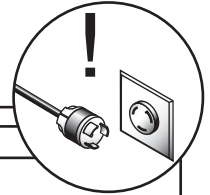

Symptom	Possible Cause	Possible Solution
Tool does not start.	<ol style="list-style-type: none"> <li>1. Power supply switched OFF, breaker tripped, fuse blown, or power supply is at fault.</li> <li>2. Motor overloaded.</li> <li>3. Motor brushes at fault.</li> <li>4. ON/OFF switch at fault.</li> <li>5. Motor at fault.</li> </ol>	<ol style="list-style-type: none"> <li>1. Ensure power supply is on/has correct voltage.</li> <li>2. Allow the motor to cool down completely and retry.</li> <li>3. Remove/replace brushes.</li> <li>4. Replace switch.*</li> <li>5. Test/repair/replace.*</li> </ol>
Tool stalls or is underpowered.	<ol style="list-style-type: none"> <li>1. Workpiece material not suitable for machine.</li> <li>2. Tool is undersized for task.</li> <li>3. Dust collection ducting problem.</li> <li>4. Motor brushes at fault.</li> <li>5. Motor bearings at fault.</li> <li>6. Motor overheated.</li> <li>7. Motor at fault.</li> </ol>	<ol style="list-style-type: none"> <li>1. Only cut wood/ensure moisture is below 20%.</li> <li>2. Use correct blade/reduce feed rate or depth of cut.</li> <li>3. Clear blockages, seal leaks, use smooth wall duct, eliminate bends, close other branches.</li> <li>4. Remove/replace brushes.</li> <li>5. Test/repair/replace.*</li> <li>6. Clean motor, let cool, and reduce workload.</li> <li>7. Test/repair/replace.*</li> </ol>
Tool has vibration or noisy operation.	<ol style="list-style-type: none"> <li>1. Motor or component loose.</li> <li>2. Blade at fault.</li> <li>3. Workpiece loose.</li> <li>4. Motor bearings at fault.</li> </ol>	<ol style="list-style-type: none"> <li>1. Inspect/replace damaged bolts/nuts, and re-tighten with thread locking fluid.</li> <li>2. Replace warped/bent blade; sharpen dull blade.</li> <li>3. Use the correct holding fixture and re-clamp workpiece.</li> <li>4. Test by rotating shaft; rotational grinding/loose shaft requires bearing replacement.*</li> </ol>
Blade does not reach 90°.	<ol style="list-style-type: none"> <li>1. Zero-stop set screw is out of adjustment.</li> <li>2. Pointer bracket is hitting before the blade reaches 90°.</li> </ol>	<ol style="list-style-type: none"> <li>1. Adjust the zero-stop set screw (see below).</li> <li>2. File down the right side of the pointer bracket until the blade can reach 90°.</li> </ol>
Cuts are rough or wavy; workpiece rips or splinters.	<ol style="list-style-type: none"> <li>1. Saw blade is dull.</li> <li>2. Incorrect blade for workpiece.</li> <li>3. Excessive force when cutting.</li> <li>4. Improper blade depth.</li> </ol>	<ol style="list-style-type: none"> <li>1. Resharpener or replace the dull blade.</li> <li>2. Replace with proper saw blade.</li> <li>3. Decrease pressure when cutting and allow saw to move through workpiece at a slower rate.</li> <li>4. Slightly increase/decrease depth of cut.</li> </ol>
Blade is burning workpiece.	<ol style="list-style-type: none"> <li>1. Saw blade is dull.</li> <li>2. Blade installed backward.</li> <li>3. Incorrect blade for workpiece.</li> </ol>	<ol style="list-style-type: none"> <li>1. Resharpener or replace the dull blade.</li> <li>2. Remove/reinstall blade correctly.</li> <li>3. Replace with proper blade.</li> </ol>

\* Solution should only be carried out by or under the supervision of qualified service personnel.



# Adjusting Zero-Stop Set Screw

The zero-stop set screw (see **Figure 27**) keeps the saw resting at exactly 90°. It can be adjusted using a 2.5mm hex wrench.

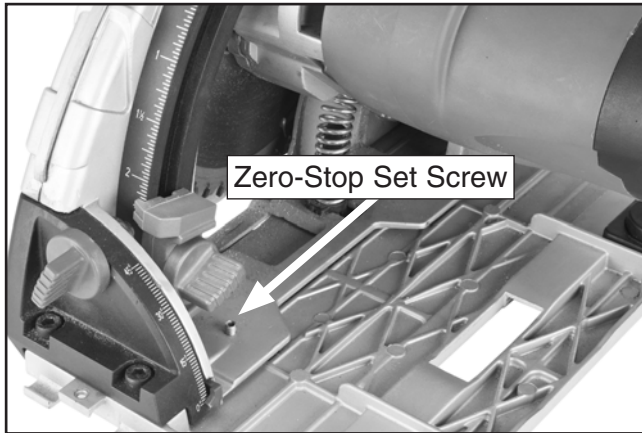

**Figure 27.** Location of zero-stop set screw.

## To adjust the zero-stop set screw:

1. Place the saw on a flat, level surface.
2. Align the outside edge of the saw with a carpenter's square or a straight, level block.
3. Using the 2.5mm hex wrench, adjust the zero-stop set screw until the outside edge of the saw is flush against your square or block.



# SECTION 7: PARTS

## T10687 Track Saw Parts Breakdown

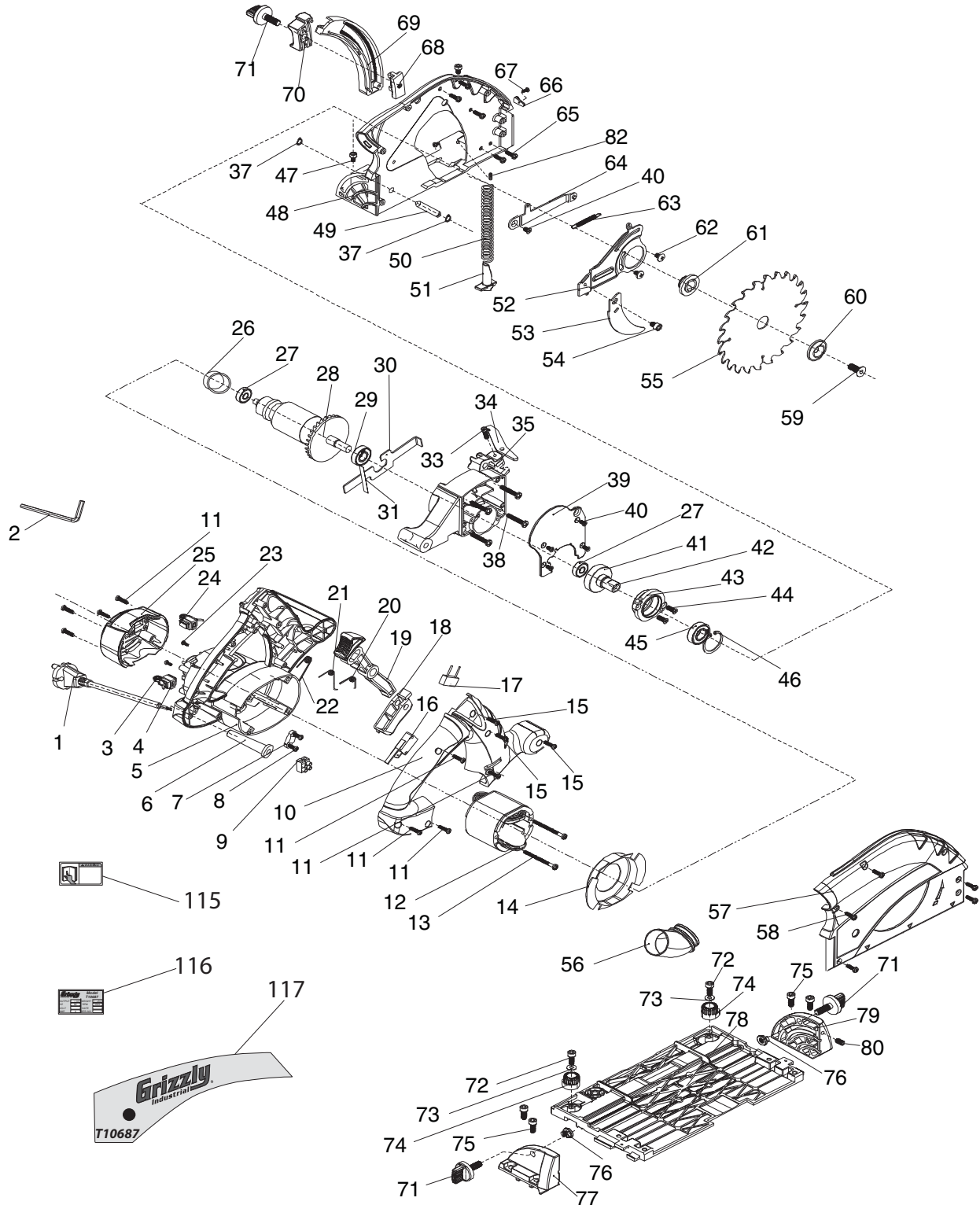

**Please Note:** We do our best to stock replacement parts whenever possible, but we cannot guarantee that all parts shown here are available for purchase. Call (800) 523-4777 or visit our online parts store at [www.grizzly.com](http://www.grizzly.com) to check for availability.



# Track Saw Parts List

REF	PART #	DESCRIPTION
1	PT10687001	POWER CORD 18G 2W 72" 1-15
2	PAW05M	HEX WRENCH 5MM
3	PT10687003	CARBON BRUSH SPRING
4	PT10687004	CARBON BRUSH HOLDER
5	PT10687005	MOTOR HOUSING
6	PT10687006	PWR CORD PROTECTOR
7	PT10687007	POWER CORD CLIP
8	PT10687008	PHLP HD TAP SCR M4.2 X 12
9	PT10687009	TERMINAL BLOCK 2 POST
10	PT10687010	HANDLE
11	PT10687011	PHLP HD TAP SCR M4.2 X 16
12	PT10687012	STATOR
13	PT10687013	PHLP HD TAP SCR M4.2 X 55
14	PT10687014	MOTOR FRONT COVER
15	PT10687015	PHLP HD TAP SCR M4.2 X 22
16	PT10687016	MICRO SWITCH
17	PT10687017	CAPACITOR
18	PT10687018	POWER TRIGGER
19	PT10687019	PLUNGE TRIGGER
20	PT10687020	RESET TORSION SPRING
21	PT10687021	PLUNGE TORSION SPRING
22	PT10687022	POWER TORSION SPRING
23	PT10687023	PHLP HD TAP SCR M3 X 8
24	PT10687024	CARBON BRUSH
25	PT10687025	BACK COVER
26	PT10687026	RUBBER BEARING SLEEVE
27	P608Z	BALL BEARING 608Z
28	PT10687028	ROTOR
29	P6001ZZ	BALL BEARING 6001ZZ
30	PT10687030	BLADE SAFETY LOCK
31	PT10687031	SAFETY SEG COIL SPRING
33	PCAP24M	CAP SCREW M5-.8 X 16
34	PT10687034	PLUNGE LOCK
35	PT10687035	GEAR BOX
38	PT10687038	GEAR BOX SCREW M4.8 X 30
39	PT10687039	GEAR BOX COVER
40	PFH30M	FLAT HD SCR M5-.8 X 8
41	PT10687041	ARBOR CYLINDER
42	PT10687042	ARBOR SHAFT
43	PT10687043	ARBOR BEARING COVER
44	PFH05M	FLAT HD SCR M5-.8 X 12

REF	PART #	DESCRIPTION
45	P6002ZZ	BALL BEARING 6002ZZ
46	PR29M	INT RETAINING RING 32MM
47	PCAP50M	CAP SCREW M5-.8 X 10
48	PT10687048	FRAME
49	PT10687049	PIVOT PIN
50	PT10687050	COMPRESSION SPRING
51	PT10687051	SPRING GUIDE
52	PT10687052	RIVING KNIFE LOWER ARM
53	PT10687053	RIVING KINFE
54	PCAP85M	CAP SCREW M6-1 X 6
55	PT10687055	SAW BLADE 160MM 48T
56	PT10687056	DUST PORT 1.5"
57	PT10687057	BLADE HOUSING
58	PS74M	PHLP HD SCR M4-.7 X 14
59	PFH68M	FLAT HD CAP SCR M8-1.25 X 20
60	PT10687060	OUTER ARBOR FLANGE
61	PT10687061	INNER ARBOR FLANGE
62	PT10687062	PAN HD SCREW M4-.7 X 14
63	PT10687063	RIVING KNIFE SPRING
64	PT10687064	RIVING KNIFE UPPER ARM
65	PT10687065	PHLP HD TAP SCR M4 X 14
66	PT10687066	ANGLE GAUGE POINTER
67	PT10687067	PHLP HD TAP SCR M3 X 5
68	PT10687068	DEPTH GAUGE SUPPORT
69	PT10687069	DEPTH GAUGE SCALE
70	PT10687070	DEPTH GAUGE
71	PT10687071	KNOB BOLT M8-1.25 X 24
72	PCAP04M	CAP SCREW M6-1 X 10
73	PW03M	FLAT WASHER 6MM
74	PT10687074	RAIL ADJUSTMENT KNOB
75	PCAP01M	CAP SCREW M6-1 X 16
76	PT10687076	SCALE NUT 8MM
77	PT10687077	LEFT TILT GUIDE
78	PT10687078	BASE PLATE
79	PT10687079	RIGHT TILT GUIDE
80	PSS04M	SET SCREW M6-1 X 12
82	PSS05M	SET SCREW M5-.8 X 10
115	PT10687115	READ MANUAL LABEL
116	PT10687116	MOTOR LABEL
117	PT10687117	GRIZZLY LOGO LABEL

## WARNING

Safety labels help reduce the risk of serious injury caused by machine hazards. If any label comes off or becomes unreadable, the owner of this machine **MUST** replace it in the original location before resuming operations. For replacements, contact (800) 523-4777 or [www.grizzly.com](http://www.grizzly.com).



# T24872 Rail Track & T25094 Accessory Pack Parts Breakdown

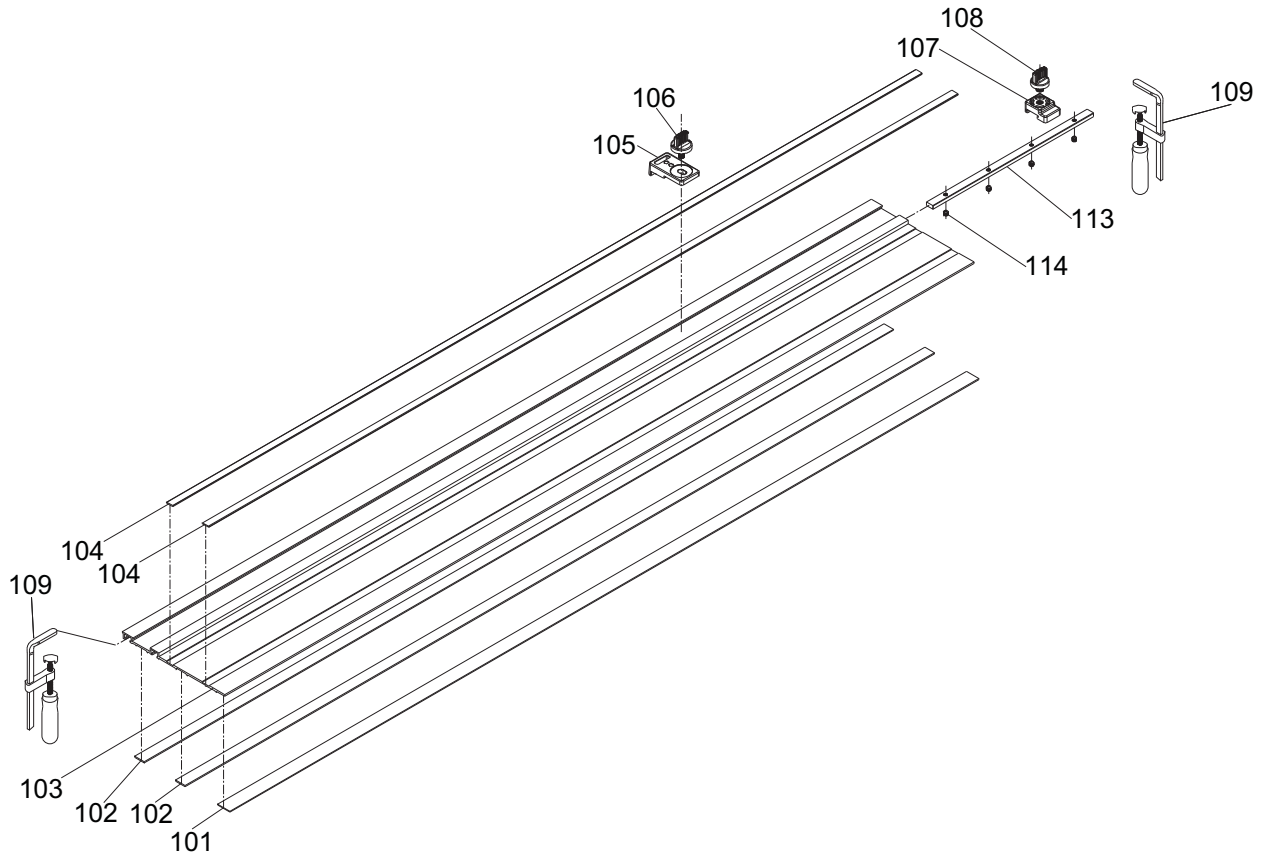

REF	PART #	DESCRIPTION
101	PT10687101	BOTTOM RUBBER STRIP
102	PT10687102	BOTTOM FOAM STRIP
103	PT10687103	RAIL TRACK BODY
104	PT10687104	TOP BLUE PLASTIC STRIP
105	PT10687105	STABILIZER BODY
106	PT10687106	KNOB BOLT 5/16-18 X 1/2

REF	PART #	DESCRIPTION
107	PT10687107	ADJUSTABLE STOP BODY
108	PT10687108	ADJUSTABLE STOP KNOB BOLT
109	PT10687109	F-CLAMP
113	PT10687113	RAIL TRACK CONNECTOR
114	PT10687114	RAIL TRACK SET SCREW







# WARRANTY CARD

Name \_\_\_\_\_  
 Street \_\_\_\_\_  
 City \_\_\_\_\_ State \_\_\_\_\_ Zip \_\_\_\_\_  
 Phone # \_\_\_\_\_ Email \_\_\_\_\_  
 Model # \_\_\_\_\_ Order # \_\_\_\_\_ Serial # \_\_\_\_\_

The following information is given on a voluntary basis. It will be used for marketing purposes to help us develop better products and services. **Of course, all information is strictly confidential.**

- How did you learn about us?
 

<input type="checkbox"/> Advertisement	<input type="checkbox"/> Friend	<input type="checkbox"/> Catalog
<input type="checkbox"/> Card Deck	<input type="checkbox"/> Website	<input type="checkbox"/> Other:
- Which of the following magazines do you subscribe to?
 

<input type="checkbox"/> Cabinetmaker & FDM	<input type="checkbox"/> Popular Science	<input type="checkbox"/> Wooden Boat
<input type="checkbox"/> Family Handyman	<input type="checkbox"/> Popular Woodworking	<input type="checkbox"/> Woodshop News
<input type="checkbox"/> Hand Loader	<input type="checkbox"/> Precision Shooter	<input type="checkbox"/> Woodsmith
<input type="checkbox"/> Handy	<input type="checkbox"/> Projects in Metal	<input type="checkbox"/> Woodwork
<input type="checkbox"/> Home Shop Machinist	<input type="checkbox"/> RC Modeler	<input type="checkbox"/> Woodworker West
<input type="checkbox"/> Journal of Light Cont.	<input type="checkbox"/> Rifle	<input type="checkbox"/> Woodworker's Journal
<input type="checkbox"/> Live Steam	<input type="checkbox"/> Shop Notes	<input type="checkbox"/> Other:
<input type="checkbox"/> Model Airplane News	<input type="checkbox"/> Shotgun News	
<input type="checkbox"/> Old House Journal	<input type="checkbox"/> Today's Homeowner	
<input type="checkbox"/> Popular Mechanics	<input type="checkbox"/> Wood	
- What is your annual household income?
 

<input type="checkbox"/> \$20,000-\$29,000	<input type="checkbox"/> \$30,000-\$39,000	<input type="checkbox"/> \$40,000-\$49,000
<input type="checkbox"/> \$50,000-\$59,000	<input type="checkbox"/> \$60,000-\$69,000	<input type="checkbox"/> \$70,000+
- What is your age group?
 

<input type="checkbox"/> 20-29	<input type="checkbox"/> 30-39	<input type="checkbox"/> 40-49
<input type="checkbox"/> 50-59	<input type="checkbox"/> 60-69	<input type="checkbox"/> 70+
- How long have you been a woodworker/metalworker?
 

<input type="checkbox"/> 0-2 Years	<input type="checkbox"/> 2-8 Years	<input type="checkbox"/> 8-20 Years	<input type="checkbox"/> 20+ Years
------------------------------------	------------------------------------	-------------------------------------	------------------------------------
- How many of your machines or tools are Grizzly?
 

<input type="checkbox"/> 0-2	<input type="checkbox"/> 3-5	<input type="checkbox"/> 6-9	<input type="checkbox"/> 10+
------------------------------	------------------------------	------------------------------	------------------------------
- Do you think your machine represents a good value?  Yes  No
- Would you recommend Grizzly Industrial to a friend?  Yes  No
- Would you allow us to use your name as a reference for Grizzly customers in your area?  
**Note: We never use names more than 3 times.**  Yes  No

10. Comments: \_\_\_\_\_  
 \_\_\_\_\_  
 \_\_\_\_\_  
 \_\_\_\_\_

CUT ALONG DOTTED LINE

FOLD ALONG DOTTED LINE

\_\_\_\_\_  
\_\_\_\_\_  
\_\_\_\_\_



Place  
Stamp  
Here



**GRIZZLY INDUSTRIAL, INC.**  
**P.O. BOX 2069**  
**BELLINGHAM, WA 98227-2069**



FOLD ALONG DOTTED LINE

Send a Grizzly Catalog to a friend:

Name \_\_\_\_\_  
Street \_\_\_\_\_  
City \_\_\_\_\_ State \_\_\_\_\_ Zip \_\_\_\_\_

TAPE ALONG EDGES--PLEASE DO NOT STAPLE

# WARRANTY & RETURNS

---

---

Grizzly Industrial, Inc. warrants every product it sells for a period of **1 year** to the original purchaser from the date of purchase. This warranty does not apply to defects due directly or indirectly to misuse, abuse, negligence, accidents, repairs or alterations or lack of maintenance. This is Grizzly's sole written warranty and any and all warranties that may be implied by law, including any merchantability or fitness, for any particular purpose, are hereby limited to the duration of this written warranty. We do not warrant or represent that the merchandise complies with the provisions of any law or acts unless the manufacturer so warrants. In no event shall Grizzly's liability under this warranty exceed the purchase price paid for the product and any legal actions brought against Grizzly shall be tried in the State of Washington, County of Whatcom.

We shall in no event be liable for death, injuries to persons or property or for incidental, contingent, special, or consequential damages arising from the use of our products.

To take advantage of this warranty, contact us by mail or phone and give us all the details. We will then issue you a "Return Number," which must be clearly posted on the outside as well as the inside of the carton. We will not accept any item back without this number. Proof of purchase must accompany the merchandise.

The manufacturers reserve the right to change specifications at any time because they constantly strive to achieve better quality equipment. We make every effort to ensure that our products meet high quality and durability standards and we hope you never need to use this warranty.

Please feel free to write or call us if you have any questions about the machine or the manual.

Thank you again for your business and continued support. We hope to serve you again soon.

# *grizzly.com*<sup>®</sup>

**TOOL WEBSITE**

Buy Direct and Save with Grizzly<sup>®</sup> – Trusted, Proven and a Great Value!  
~Since 1983~

*Visit Our Website Today For  
Current Specials!*

**ORDER  
24 HOURS A DAY!  
1-800-523-4777**

